

THIS DRAWING IS UNPUBLISHED. RELEASED FOR PUBLICATION
 © COPYRIGHT - By - ALL RIGHTS RESERVED.

LOC	DIST	REVISIONS			
P	LTR	DESCRIPTION	DATE	DWN	APVD
AF	50	A2	REVISED PER ECR-11-006644	05APR11	HMR GJ

- CONTINUOUS STRIP ON REELS
- WIRE RANGE FOR NEW APPLICATIONS: 3.75–5.07mm²[7400–10,000CMA]
(WIRE RANGE APPROVED FOR APPLICATIONS IMPLEMENTED PRIOR TO 2005: 4000–10,000 CMA).
- CRIMP WIDTH: 4.57[.180]F TYPE. CRIMP HEIGHT IN INCHES (+/- .002)=(TOTAL CMA OF WIRES + 20044)/288890.

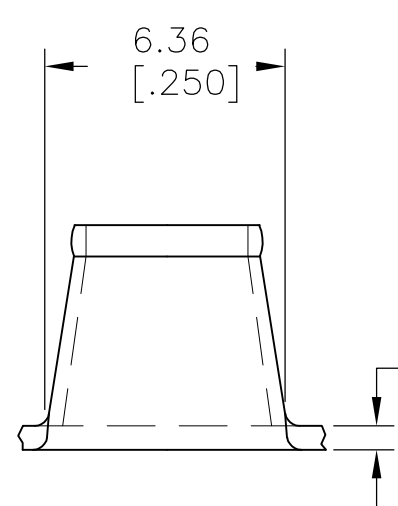
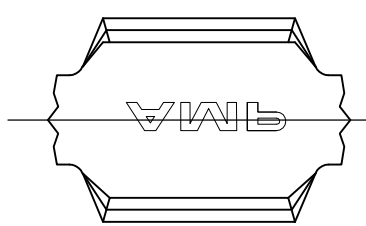

0.64±0.03
[.025±.001]

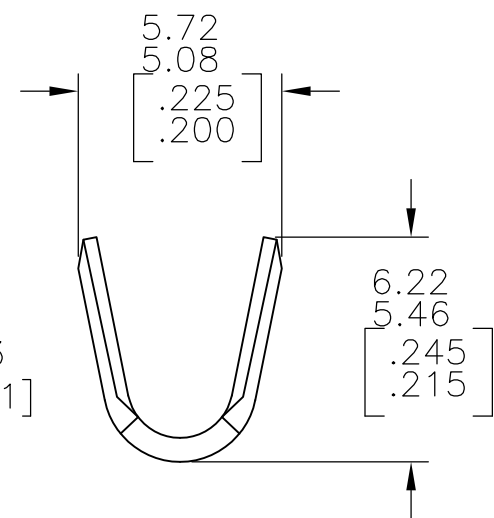

62357-1
PART NO

THIS DRAWING IS A CONTROLLED DOCUMENT.		DWN	jr_ruth	24NOV04	STE TE Connectivity		
DIMENSIONS: mm [INCHES]		CHK	G PORTA	24NOV04			
TOLERANCES UNLESS OTHERWISE SPECIFIED:		APVD	G PORTA	24NOV04	NAME		
0 PLC ± -		PRODUCT SPEC			SPLICE		
1 PLC ± -		APPLICATION SPEC			RESTRICTED TO		
2 PLC ± 0.25[.010]		114-2088			SIZE	CAGE CODE	DRAWING NO
3 PLC ± -		WEIGHT -			A3	00779	C-62357
4 PLC ± -		CUSTOMER DRAWING			SCALE	SHEET	REV
ANGLES ± 5°		TEMP 1 BRASS			1:1	1 OF 1	A2
FINISH -							